



How to Identify Fluid Ports and Connectors

A guide to North American, British, Japanese, German (DIN metric), and ISO connections



How to measure threads

Use a thread pitch gauge to determine the number of threads per inch or the distance between threads in metric connections. Place the gauge on the threads until the fit is snug. Match your measurements with the tables in this guide.

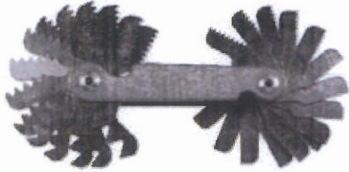

Measure the thread diameter with an I.D./O.D. caliper. When comparing your measurements with the dimensions shown in this guide, remember threads can become worn and distorted from use. Your measurements may not match exactly to the figures shown in our tables.

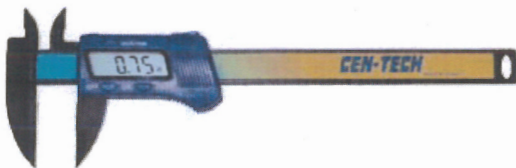

How to measure four-bolt flanges

First measure the port hole diameter using a caliper. Next, measure the longest bolt hole spacing from center to center or measure the flange head diameter.

Dash numbers

Most fluid pipe and tube sizes in the United States are identified by dash numbers, abbreviations that make ordering components easier. Dash numbers are commonly expressed as the numerator of a fraction where the denominator is always 16. For example, a -04 port or connector is 4/16 or 1/4 inch. Dash numbers are usually nominal (in name only).

Metric threads are actual size and do not use dash numbers. For example, M16x1.5 = 16 mm thread O.D. with 1.5 mm between each thread.

Table of Contents

North American Connections

National Pipe Tapered Fuel (NPTF)	4
National Pipe Straight Mechanical (NPSM).	5
SAE J514 37° Flare Hydraulic (JIC)	6
SAE J512 45° Flare	7
SAE J1926-1 Straight Thread O-Ring Boss (ORB)	8
SAE J514 Flareless Tube Fitting	9
SAE J1453 O-Ring Face Seal (ORFS)	10
SAE J512 Inverted Flare.	11
O-Ring Pilot Threads.	12

ISO Connections

ISO/DIS 6162 Four-Bolt Flange (includes SAE J518)	13
ISO 1179-1 Flat Face Port with BSPP Threads	14
ISO 9974-1 Flat Face Port with Metric Threads	15
ISO 6149 Port and Stud Ends with ISO 261 Threads and O-Ring Seal .	16

German Connections

DIN 7631 Series.	17
DIN 2353 Series.	18

British Connections

British Standard Pipe, Parallel (BSPP)	20
British Standard Pipe, Taper (BSPT)	21

Japanese Connections

JIS 30° Flare	22
Komatsu 30° Flare with Metric Threads	23

National Pipe Tapered Fuel (NPTF)

This connection is still widely used in fluid power systems, even though it is not recommended by the National Fluid Power Association (NFPA) for use in hydraulic applications. The thread is tapered and the seal takes place by deformation of the threads.

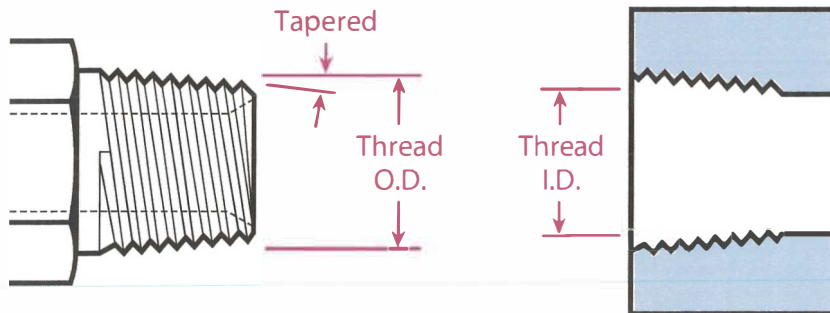

NPTF Thread Tip: Measure the thread diameter and subtract one quarter inch to find the nominal pipe size.

Inch Size	Dash Size	Nominal Thread Size	Male Thread O.D.	Female Thread I.D.
1/8	02	1/8 - 27	13/32 (0.41")	3/8 (0.38")
1/4	04	1/4 - 18	17/32 (0.54")	1/2 (0.49")
3/8	06	3/8 - 18	11/16 (0.68")	5/8 (0.63")
1/2	08	1/2 - 14	27/32 (0.84")	25/32 (0.77")
3/4	12	3/4 - 14	1 1/16 (1.05")	1 (0.98")
1	16	1 - 11 1/2	1 5/16 (1.32")	1 1/4 (1.24")
1 1/4	20	1 1/4 - 11 1/2	1 21/32 (1.66")	1 19/32 (1.58")
1 1/2	24	1 1/2 - 11 1/2	1 29/32 (1.90")	1 13/16 (1.82")
2	32	2 - 11 1/2	2 3/8 (2.38")	2 5/16 (2.30")

National Pipe Straight Mechanical (NPSM)

This connection is sometimes used in fluid power systems. The female half has a straight thread and an inverted 30° seat. The male half has a straight thread and a 30° internal chamfer. The 30° seat of the female seals against the chamfer on the male. The threads hold the connection mechanically.

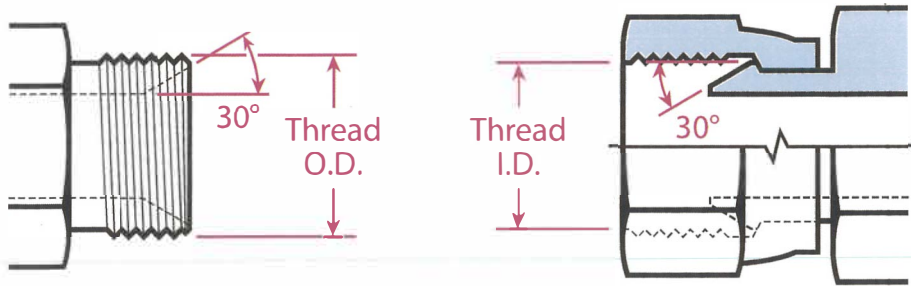

A properly chamfered NPTF male will also seal with a NPSM female.

Inch Size	Dash Size	Nominal Thread Size	Male Thread O.D.	Female Thread I.D.
1/8	02	1/8 - 27	13/32 (0.41")	3/8 (0.38")
1/4	04	1/4 - 18	17/32 (0.54")	1/2 (0.49")
3/8	06	3/8 - 18	11/16 (0.68")	5/8 (0.63")
1/2	08	1/2 - 14	27/32 (0.84")	25/32 (0.77")
3/4	12	3/4 - 14	1 1/16 (1.05")	1 (0.98")
1	16	1 - 11 1/2	1 5/16 (1.32")	1 1/4 (1.24")
1 1/4	20	1 1/4 - 11 1/2	1 21/32 (1.66")	1 19/32 (1.58")
1 1/2	24	1 1/2 - 11 1/2	1 29/32 (1.90")	1 13/16 (1.82")
2	32	2 - 11 1/2	2 3/8 (2.38")	2 5/16 (2.30")

SAE J514 37° Flare Hydraulic (JIC)

Originally named for the Joint Industrial Commission (JIC), this connection is very common in fluid power systems. Both the male and female halves of this connection have 37° seats. The seal takes place by establishing a line of contact between the male flare and the female cone seat. The threads hold the connection mechanically.

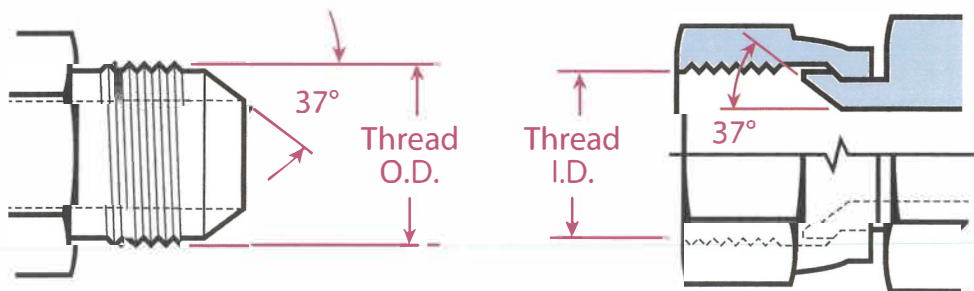

Tube Size	Dash Size	Nominal Thread Size	Male Thread O.D.	Female Thread I.D.
1/8	02	5/16 - 24	5/16 (0.31")	9/32 (0.27")
3/16	03	3/8 - 24	3/8 (0.38")	11/32 (0.34")
1/4	04	7/16 - 20	7/16 (0.44")	13/32 (0.39")
5/16	05	1/2 - 20	1/2 (0.50")	15/32 (0.45")
3/8	06	9/16 - 18	9/16 (0.56")	17/32 (0.51")
1/2	08	3/4 - 16	3/4 (0.75")	11/16 (0.69")
5/8	10	7/8 - 14	7/8 (0.88")	13/16 (0.81")
3/4	12	1 1/16 - 12	1 1/16 (1.06")	1 (0.98")
7/8	14	1 3/16 - 12	1 3/16 (1.19")	1 1/8 (1.10")
1	16	1 5/16 - 12	1 5/16 (1.31")	1 1/4 (1.23")
1 1/4	20	1 5/8 - 12	1 5/8 (1.63")	1 9/16 (1.54")
1 1/2	24	1 7/8 - 12	1 7/8 (1.88")	1 13/16 (1.79")
2	32	2 1/2 - 12	2 1/2 (2.50")	2 7/16 (2.42")

SAE J512 45° Flare

This connection is very common in refrigeration, automotive and truck piping systems. The connectors are frequently made of brass. Both the male and female halves of this connection have 45° seats. The seal takes place between the male flare and the female cone seat. The threads hold the connection mechanically.

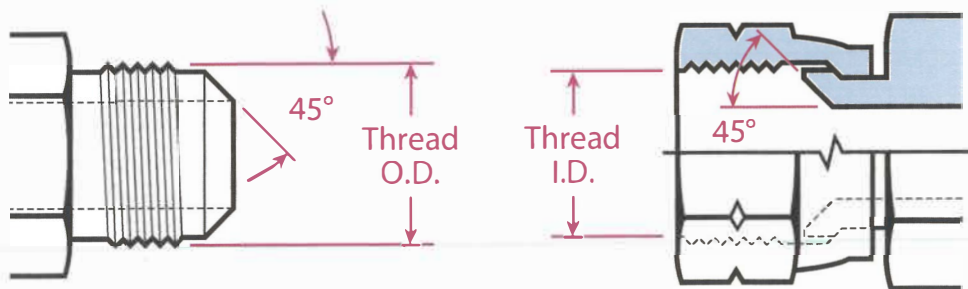

Tube Size	Dash Size	Nominal Thread Size	Male Thread O.D.	Female Thread I.D.
1/8	02	5/16 - 24	5/16 (0.31")	9/32 (0.27")
3/16	03	3/8 - 24	3/8 (0.38")	11/32 (0.34")
1/4	04	7/16 - 20	7/16 (0.44")	13/32 (0.39")
5/16	05	1/2 - 20	1/2 (0.50")	15/32 (0.45")
3/8	06	5/8 - 18	5/8 (0.63")	9/16 (0.57")
1/2	08	3/4 - 16	3/4 (0.75")	11/16 (0.69")
5/8	10	7/8 - 14	7/8 (0.88")	13/16 (0.81")
3/4	12	1 1/16 - 14	1 1/16 (1.06")	1 (0.99")
7/8	14	1 3/16 - 12	1 3/16 (1.19")	1 1/8 (1.10")
1	16	1 5/16 - 12	1 5/16 (1.31")	1 1/4 (1.23")

Caution: In sizes -02, -03, -04, 05, -08 and -10, the threads of the SAE 37° flare and SAE 45° flare are the same. However, the sealing surface angles are not the same.



SAE J1926-1 Straight Thread O-Ring Port

ISO 11296-1, Conforms to MS16142, UN/UNF Threads

This port connection is recommended for optimum leakage control in medium and high pressure hydraulic systems. The male connector has a straight thread and an O-ring. The female port has a straight thread, a machined surface (minimal spotface) and a chamfer to accept the O-ring. The seal takes place by compressing the O-ring into the chamfer. The threads hold the connection mechanically.

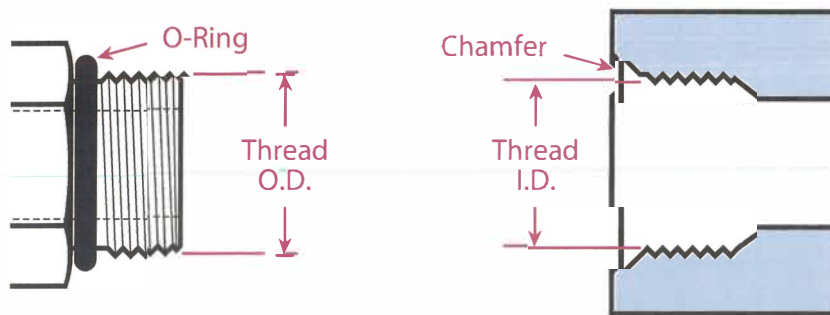

Nominal Port Size	Dash Size	Nominal Thread Size	Male Thread O.D.	Female Thread I.D.
1/8"	02	5/16 - 24	5/16 (0.31")	9/32 (0.27")
3/16"	03	3/8 - 24	3/8 (0.38")	11/32 (0.34")
1/4"	04	7/16 - 20	7/16 (0.44")	13/32 (0.39")
5/16"	05	1/2 - 20	1/2 (0.50")	15/32 (0.45")
3/8"	06	9/16 - 18	9/16 (0.56")	17/32 (0.51")
1/2"	08	3/4 - 16	3/4 (0.75")	11/16 (0.69")
5/8"	10	7/8 - 14	7/8 (0.88")	13/16 (0.81")
3/4"	12	1 1/16 - 12	1 1/16 (1.06")	1 (0.98")
7/8"	14	1 3/16 - 12	1 3/16 (1.19")	1 1/8 (1.10")
1"	16	1 5/16 - 12	1 5/16 (1.31")	1 1/4 (1.23")
1 1/4"	20	1 5/8 - 12	1 5/8 (1.63")	1 9/16 (1.54")
1 1/2"	24	1 7/8 - 12	1 7/8 (1.88")	1 13/16 (1.79")
2"	32	2 1/2 - 12	2 1/2 (2.50")	2 7/16 (2.42")

SAE J514 Flareless Tube Fitting

The male connector has parallel threads and a 24° seat. The female half of this connection incorporates a bite-type ferrule/sleeve used in conjunction with a tube and a female nut. When the nut is tightened, the seal is made between the sleeve and the 24° seat. A seal is also made between the sleeve and the tubing. The threads hold the connection mechanically.

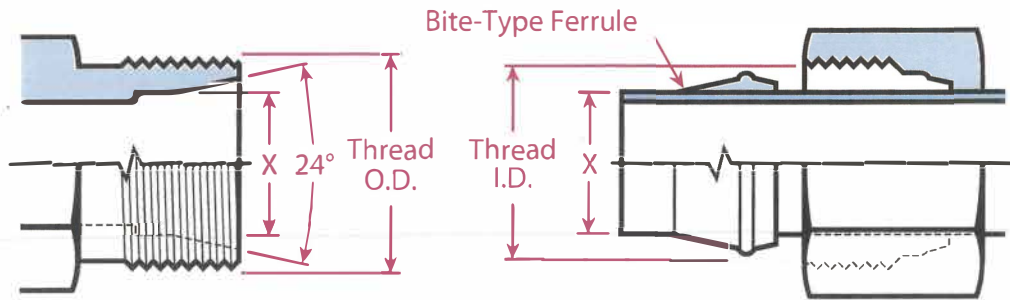

Tube O.D. (X)	Dash Size	Nominal Thread Size	Male Thread O.D.	Female Thread I.D.
1/8"	02	5/16 - 24	5/16 (0.31")	9/32 (0.27")
3/16"	03	3/8 - 24	3/8 (0.38")	11/32 (0.34")
1/4"	04	7/16 - 20	7/16 (0.44")	13/32 (0.39")
5/16"	05	1/2 - 20	1/2 (0.50")	15/32 (0.45")
3/8"	06	9/16 - 18	9/16 (0.56")	17/32 (0.51")
1/2"	08	3/4 - 16	3/4 (0.75")	11/16 (0.69")
5/8"	10	7/8 - 14	7/8 (0.88")	13/16 (0.81")
3/4"	12	1 1/16 - 12	1 1/16 (1.06")	1 (0.98")
7/8"	14	1 3/16 - 12	1 3/16 (1.19")	1 1/8 (1.10")
1"	16	1 5/16 - 12	1 5/16 (1.31")	1 1/4 (1.23")
1 1/4"	20	1 5/8 - 12	1 5/8 (1.63")	1 9/16 (1.54")
1 1/2"	24	1 7/8 - 12	1 7/8 (1.88")	1 13/16 (1.79")
2"	32	2 1/2 - 12	2 1/2 (2.50")	2 7/16 (2.42")

SAE J1453 O-Ring Face Seal

This connection offers the very best leakage control available today. The male connector has a straight thread and O-ring in the face. The female has a straight thread and a machined flat face. The seal takes place by compressing the O-ring onto the flat face of the female, similar to a flange type fitting. The threads hold the connection mechanically.

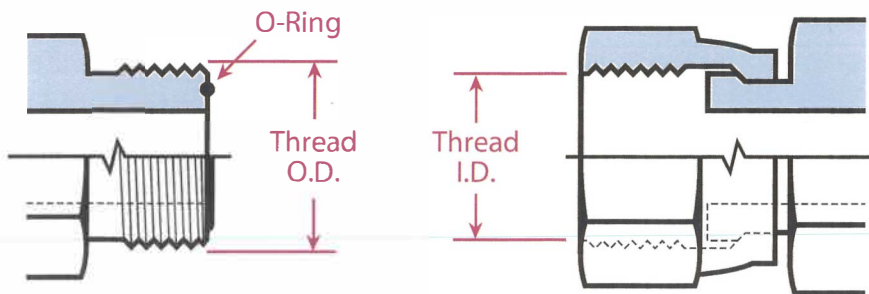

Inch Size	Dash Size	Nominal Thread Size	Male Thread O.D.	Female Thread I.D.
1/4	04	9/16 - 18	9/16 (0.56")	17/32 (0.51")
3/8	06	11/16 - 16	11/16 (0.69")	5/8 (0.63")
1/2	08	13/16 - 16	13/16 (0.82")	3/4 (0.75")
5/8	10	1 - 14	1 (1.00")	15/16 (0.93")
3/4	12	1 3/16 - 12	1 3/16 (1.19")	1 1/8 (1.11")
1	16	1 7/16 - 12	1 7/16 (1.44")	1 3/4 (1.36")
1 1/4	20	1 11/16 - 12	1 11/16 (1.69")	1 5/8 (1.61")
1 1/2	24	2 - 12	2 (2.00")	1 15/16 (1.92")

North American Connections

SAE J512 Inverted Flare

This connection is frequently used in automotive systems. The male connector can either be a 45° flare in the tube fitting form or a 42° seat in the machined adapter form. The female has a straight thread with a 42° inverted flare. The seal takes place on the flared surfaces. The threads hold the connection mechanically.

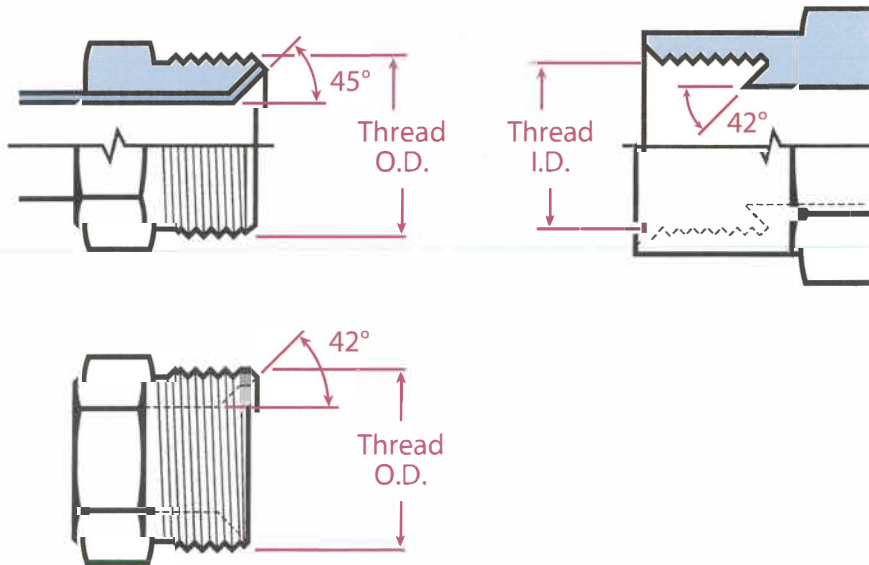

Inch Size	Dash Size	Nominal Thread Size	Male Thread O.D.	Female Thread I.D.
1/8	02	5/16 - 28	5/16 (0.32")	9/32 (0.28")
3/16	03	3/8 - 24	3/8 (0.38")	11/32 (0.34")
1/4	04	7/16 - 24	7/16 (0.44")	13/32 (0.40")
5/16	05	1/2 - 20	1/2 (0.50")	15/32 (0.45")
3/8	06	5/8 - 18	5/8 (0.63")	9/16 (0.57")
7/16	07	1 1/16 - 18	1 1/16 (0.69")	5/8 (0.63")
1/2	08	3/4 - 18	3/4 (0.75")	23/32 (0.70")
5/8	10	7/8 - 18	7/8 (0.88")	13/16 (0.82")
3/4	12	1 1/16 - 16	1 1/16 (1.06")	1 (1.00")



O-Ring Pilot Threads

This connection, sometimes known as Beadlock, is common to air conditioning systems, both in vehicle and commercial applications. Both the male and female halves of the connection have a pilot, either long or short. The seal takes place by compressing an O-ring adjacent to the bead of the tube. The threads hold the connection mechanically.

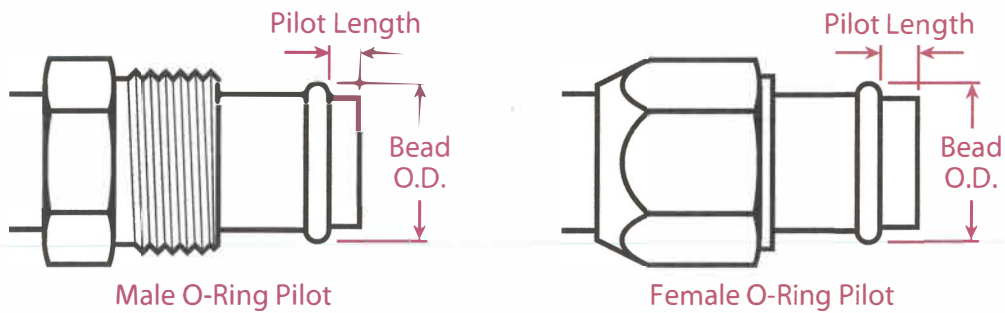

Inch Size	Dash Size	Male O-Ring Pilot Thread		Female O-Ring Pilot Thread	
		Nominal Thread Size	Male Thread O.D.	Nominal Thread Size	Female Thread I.D.
3/8	06	5/8 - 18	5/8 (0.62")	5/8 - 18	9/16 (0.57")
1/2	08	3/4 - 18	3/4 (0.75")	3/4 - 16	11/16 (0.69")
5/8	10	7/8 - 18	7/8 (0.87")	7/8 - 14	13/16 (0.81")
3/4	12	1 1/16 - 16	1 1/16 (1.06")	1 1/16 - 14	1 (0.99")

Inch Size	Nominal Tube Size	Long Pilot		Short Pilot	
		Bead O.D.	Pilot Length	Bead O.D.	Pilot Length
3/8	06	0.52"	0.28"	0.52"	0.19"
1/2	08	0.64"	0.39"	0.64"	0.19"
5/8	10	0.77"	0.39"	0.77"	0.19"
3/4	12	0.91"	0.39"	0.91"	0.19"



ISO Connections

ISO 6162 Four-Bolt Flange (includes SAE J518)

Interchangeable with DIN 20066 and JIS B 8363, except for the bolt sizes.

This connection is commonly used worldwide to connect larger size hose and tubing (1/2" to 3") in fluid power systems. An O-ring, inserted into a ring groove in the flange head, seals on a smooth faced female port, and is held in place by two clamp halves and four bolts in rectangular pattern.

ISO 6162 / SAE J518 flanges come in two pressure classes: the standard series Code 61 and the high pressure (6,000 psi) Code 62.

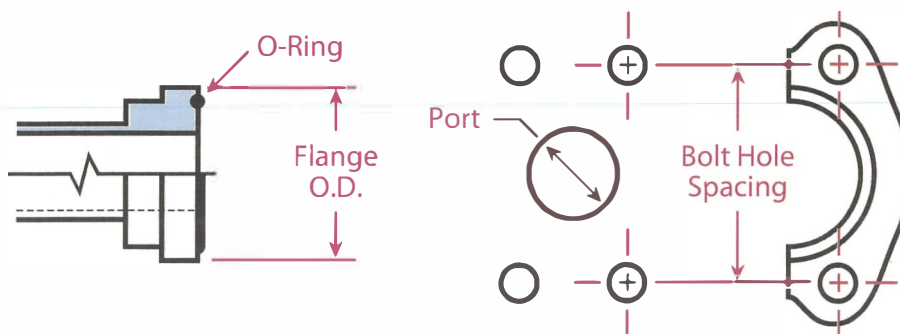

Port/ Inch Size	Dash Size	Code 61 Bolt Hole Spacing	Code 61 Flange Head Diameter	Code 62 Bolt Hole Spacing	Code 62 Flange Head Diameter
1/2	08	1 1/2 (1.50")	1 3/16 (1.19")	1 19/32 (1.59")	1 1/4 (1.25")
3/4	12	1 7/8 (1.88")	1 1/2 (1.50")	2 (2.00")	1 5/8 (1.63")
1	16	2 1/16 (2.06")	1 3/4 (1.75")	2 1/4 (2.25")	1 7/8 (1.88")
1 1/4	20	2 5/16 (2.31")	2 (2.00")	2 5/8 (2.63")	2 1/8 (2.13")
1 1/2	24	2 3/4 (2.75")	2 3/8 (2.38")	3 1/8 (3.13")	2 1/2 (2.50")
2	32	3 1/16 (3.06")	2 13/32 (2.81")	3 13/16 (3.81")	3 1/8 (3.13")
2 1/2	40	3 1/2 (3.50")	3 5/16 (3.31")	n/a	n/a
3	48	4 3/16 (4.19")	4 (4.00")	n/a	n/a

Note: CAT thick flanges have a flange thickness of 0.56" (all sizes) to interchange with Caterpillar® split flanges. All other CAT flange dimensions are identical to Code 62.



ISO 1179-1 Flat Face Port with BSPP Threads

DIN 3852, Part 2 • ISO 228-1 "G" Threads

Parallel threads seal using various sealing rings or washers, such as O-rings, bonded seals or metal to metal seals. For thread dimensions, please see the British Standard Pipe, Parallel (BSPP) thread dimensions on page 20.

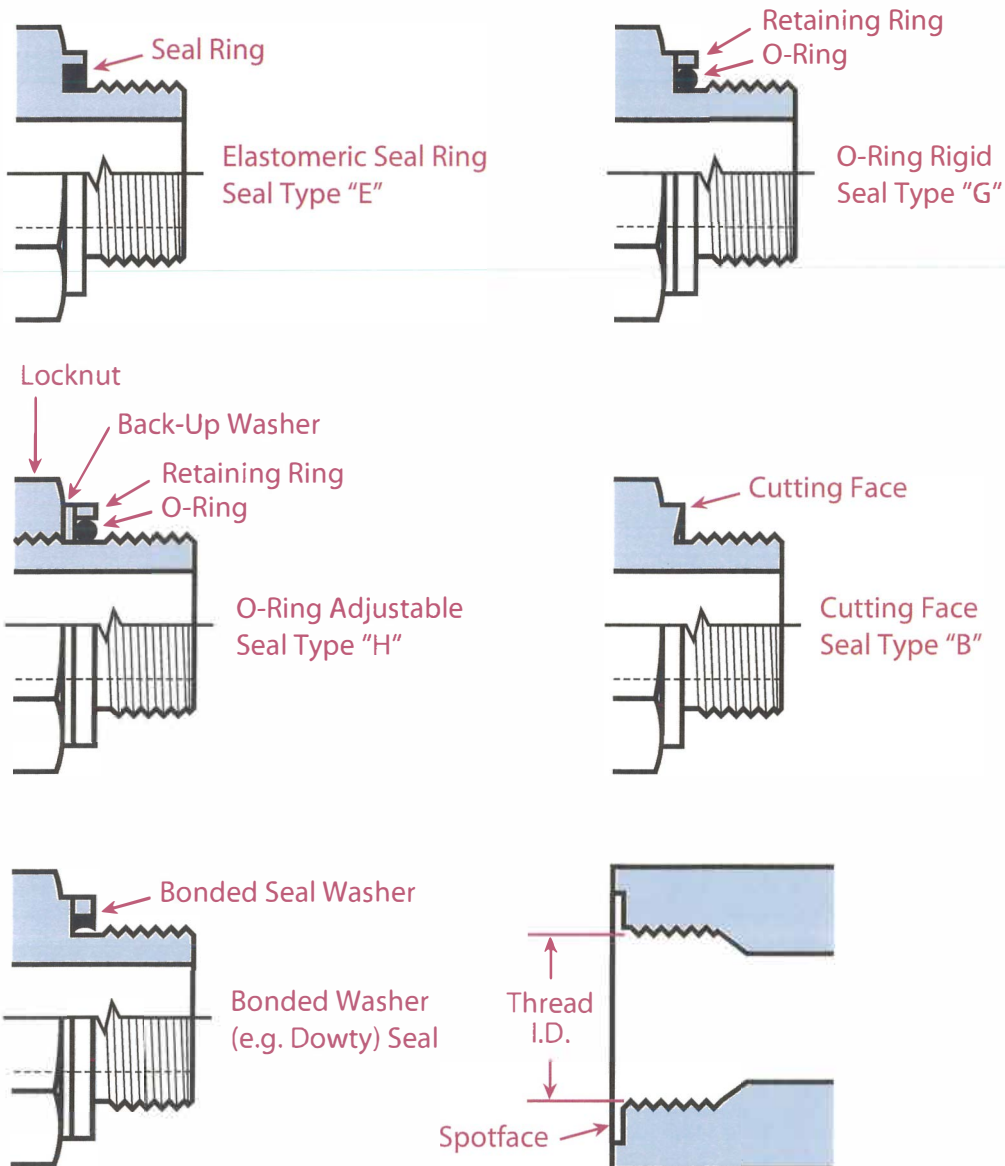



ISO 9974-1 Flat Face Port with Metric Threads

DIN 3852, Part 1

Metric ISO 261 "M" Thread

This connection is similar to ISO 1179-1, except for the metric threads. The fittings have parallel threads and seal using various sealing rings or washers or metal to metal seals.

For illustration, please see the diagrams of ISO 1179-1 on the opposite page.

Metric Thread Size	Male Thread O.D.	Female Thread I.D.
M8 x 1,0	8 mm	7 mm
M10 x 1,0	10 mm	9 mm
M12 x 1,5	12 mm	10,5 mm
M14 x 1,5	14 mm	12,5 mm
M16 x 1,5	16 mm	14,5 mm
M18 x 1,5	18 mm	16,5 mm
M20 x 1,5	20 mm	18,5 mm
M22 x 1,5	22 mm	20,5 mm
M24 x 1,5	24 mm	22,5 mm
M26 x 1,5	26 mm	24,5 mm
M27 x 2,0	27 mm	25 mm
M33 x 2,0	33 mm	31 mm
M36 x 2,0	36 mm	34 mm
M42 x 2,0	42 mm	40 mm
M45 x 2,0	45 mm	43 mm
M48 x 2,0	48 mm	46 mm



ISO 6149 Port and Stud Ends

ISO 261 Metric Threads and O-Ring Seal

This port connection is similar to the SAE J1926-1 Straight Thread O-Ring Port, except for the metric threads. The male connector has a straight metric thread and an O-ring. The female port has a straight metric thread, a machined surface (minimum spotface) and a chamfer to accept the O-ring. The seal is created by compressing the O-ring into the chamfer, and the threads hold the connection mechanically.

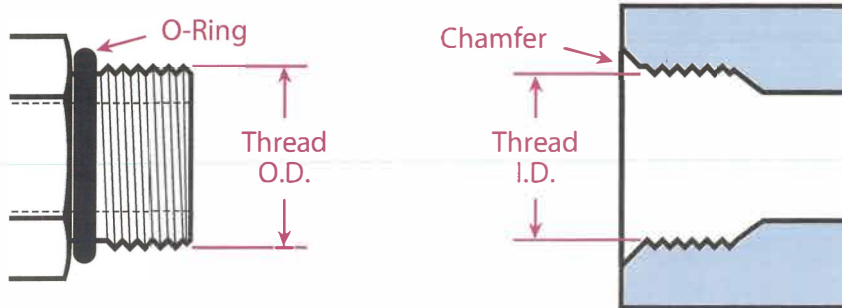

Metric Thread Size	Male Thread O.D.	Female Thread I.D.
M8 x 1,0	8 mm	7 mm
M10 x 1,0	10 mm	9 mm
M12 x 1,5	12 mm	10,5 mm
M14 x 1,5 *	14 mm	12,5 mm
M16 x 1,5	16 mm	14,5 mm
M18 x 1,5	18 mm	16,5 mm
M22 x 1,5	22 mm	20,5 mm
M27 x 2,0	27 mm	25 mm
M33 x 2,0	33 mm	31 mm
M42 x 2,0	42 mm	40 mm
M48 x 2,0	48 mm	46 mm
M60 x 2,0	60 mm	58 mm

* M14 x 1,5 is recommended for diagnostic port applications

German Connections

DIN 7631 Series

This thread is frequently used in hydraulic systems. The male connector has a straight metric thread and a 60° (included angle) recessed cone. The female has a straight thread and a tapered nose/globeseal seat. The seal takes place between the cone of the male and nose of the tapered nose/globeseal flareless swivel. The threads hold the connection mechanically.

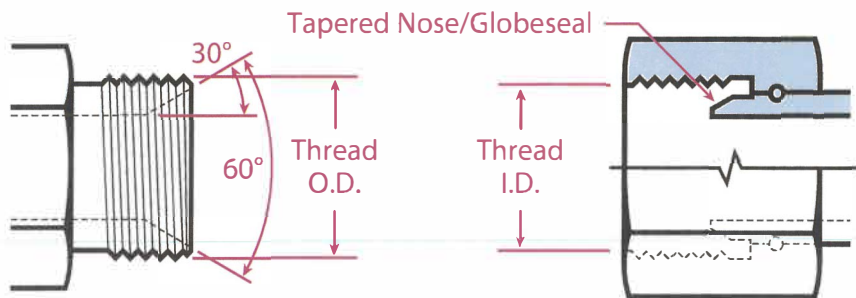

Use with Pipe/ Tube O.D.	Metric Thread Size	Male Thread O.D.	Female Thread I.D.
6 mm	M12 x 1,5	12 mm	10,5 mm
8 mm	M14 x 1,5	14 mm	12,5 mm
10 mm	M16 x 1,5	16 mm	14,5 mm
12 mm	M18 x 1,5	18 mm	16,5 mm
15 mm	M22 x 1,5	22 mm	20,5 mm
18 mm	M26 x 1,5	26 mm	24,5 mm
22 mm	M30 x 1,5	30 mm	28,5 mm
28 mm	M38 x 1,5	38 mm	36,5 mm
35 mm	M45 x 1,5	45 mm	43,5 mm
52 mm	M52 x 1,5	52 mm	50,5 mm

German Connections

DIN 2353 Series

This metric system consists of one male and three female connectors, all of which have straight metric threads. Sealing takes place between the 24° seat in the male connector and the respective sealing areas in the female connectors. DIN 2353 includes light "L" series and a heavy "S" series.

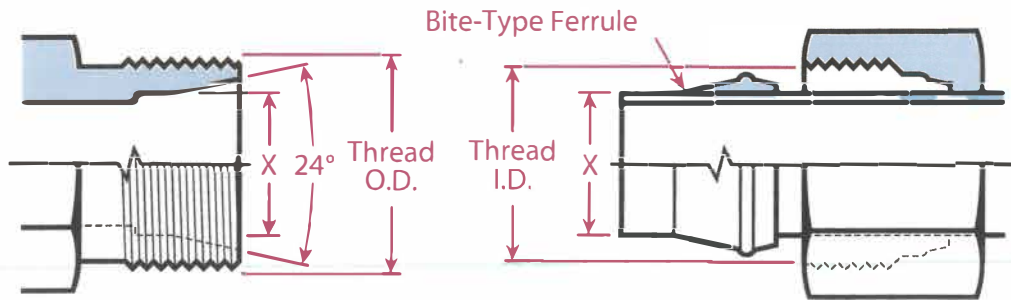

24° / 60° Cone

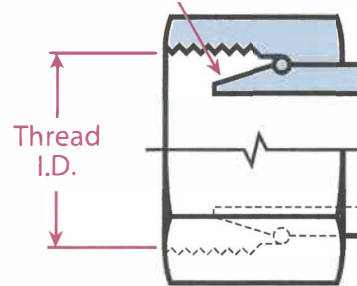

24° Taper with O-Ring

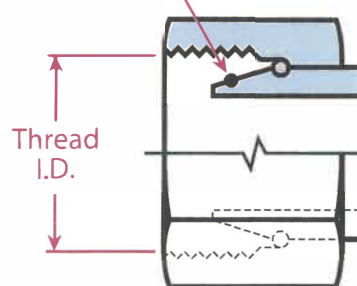



DIN 2353 Series (Continued)

Light Series Tube O.D. (‘X’ Dim.)	Heavy Series Tube O.D. (‘X’ Dim.)	Metric Thread Size	Male Thread O.D.	Fem. Thread I.D.
6 mm		M12 x 1,5	12 mm	10,5 mm
8 mm	6 mm	M14 x 1,5	14 mm	12,5 mm
10 mm	8 mm	M16 x 1,5	16 mm	14,5 mm
12 mm	10 mm	M18 x 1,5	18 mm	16,5 mm
	12 mm	M20 x 1,5	20 mm	18,5 mm
15 mm	14 mm	M22 x 1,5	22 mm	20,5 mm
	16 mm	M24 x 1,5	24 mm	22,5 mm
18 mm		M26 x 1,5	26 mm	24,5 mm
22 mm	20 mm	M30 x 2,0	30 mm	28 mm
28 mm	25 mm	M36 x 2,0	36 mm	34 mm
	30 mm	M42 x 2,0	42 mm	40 mm
35 mm		M45 x 2,0	45 mm	43 mm
42 mm	38 mm	M52 x 2,0	52 mm	50 mm



British Connections

British Standard Pipe, Parallel (BSPP)

The BSPP (parallel) male connection is similar to, but not interchangeable with, the American NPSM male. The thread pitches are different in most sizes. The female swivel BSPP has a tapered nose, which seals on the cone seat of the male.

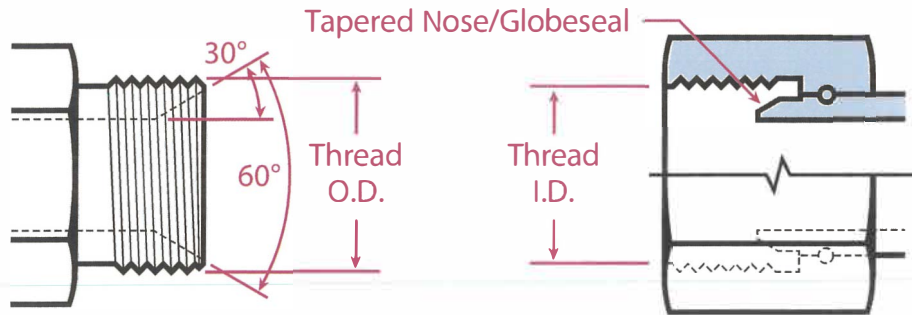

Inch Size	Dash Size	Nominal Thread Size	Male Thread O.D.	Female Thread I.D.
1/8	02	1/8 - 28	3/8 (0.38")	11/32 (0.35")
1/4	04	1/4 - 19	33/64 (0.52")	15/32 (0.47")
3/8	06	3/8 - 19	21/32 (0.65")	19/32 (0.60")
1/2	08	1/2 - 14	13/16 (0.82")	3/4 (0.75")
5/8	10	5/8 - 14	7/8 (0.88")	13/16 (0.80")
3/4	12	3/4 - 14	1 1/32 (1.04")	31/32 (0.97")
1	16	1 - 11	1 5/16 (1.30")	1 7/32 (1.22")
1 1/4	20	1 1/4 - 11	1 21/32 (1.65")	1 9/16 (1.56")
1 1/2	24	1 1/2 - 11	1 7/8 (1.88")	1 25/32 (1.79")
2	32	2 - 11	2 11/32 (2.35")	2 1/4 (2.26")

British Standard Pipe threads are sometimes identified as "G" (for parallel threads) or "R" (for tapered threads) followed by a fractional dimension.

Example: 1/2 - 14 BSPP may be expressed as G 1/2



British Standard Pipe, Tapered (BSPT)

The BSPT (tapered) male connector is similar to American NPTF, but the thread pitches are different in most sizes. The thread form and diameters are close, but not identical. Sealing is accomplished by distorting the threads. A properly chamfered BSPT male will also seal with a BSPP female swivel.

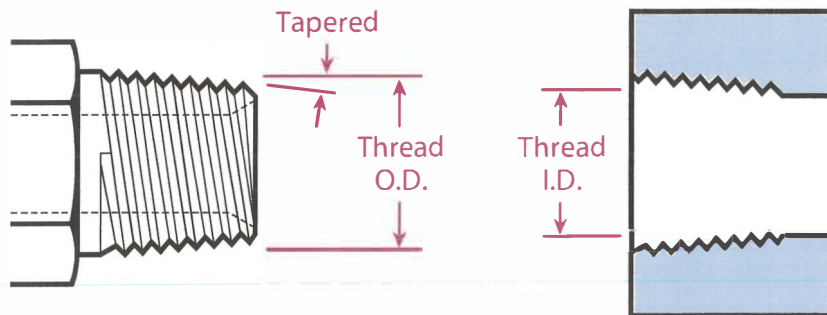

Inch Size	Dash Size	Nominal Thread Size	Male Thread O.D.	Female Thread I.D.
1/8	02	1/8 - 28	3/8 (0.38")	11/32 (0.35")
1/4	04	1/4 - 19	33/64 (0.52")	15/32 (0.47")
3/8	06	3/8 - 19	21/32 (0.65")	19/32 (0.60")
1/2	08	1/2 - 14	13/16 (0.82")	3/4 (0.75")
5/8	10	5/8 - 14	7/8 (0.88")	13/16 (0.80")
3/4	12	3/4 - 14	1 1/32 (1.04")	31/32 (0.97")
1	16	1 - 11	1 5/16 (1.30")	1 7/32 (1.22")
1 1/4	20	1 1/4 - 11	1 21/32 (1.65")	1 9/16 (1.56")
1 1/2	24	1 1/2 - 11	1 7/8 (1.88")	1 25/32 (1.79")
2	32	2 - 11	2 11/32 (2.35")	2 1/4 (2.26")

British Standard Pipe threads are sometimes identified as "G" (for parallel threads) or "R" (for tapered threads) followed by a fractional dimension.

Example: 1/2 - 14 BSPT may be expressed as R 1/2



Japanese Connections

JIS 30° Flare

The Japanese JIS 30° flare connection is similar to the American SAE 37° flare (also known as JIC), except for the 30° seat angle and the JIS B 0202 thread dimensions, which are the same as BSPP.

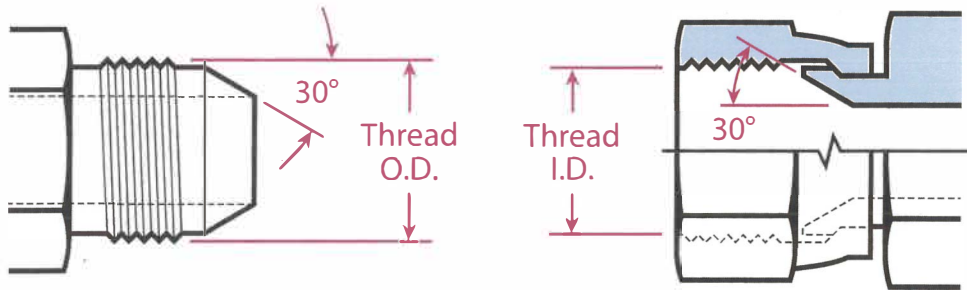

Inch Size	Dash Size	Nominal Thread Size	Male Thread O.D.	Female Thread I.D.
1/8	02	1/8 - 28	3/8 (0.38")	11/32 (0.35")
1/4	04	1/4 - 19	33/64 (0.52")	15/32 (0.47")
3/8	06	3/8 - 19	21/32 (0.65")	19/32 (0.60")
1/2	08	1/2 - 14	13/16 (0.82")	3/4 (0.75")
5/8	10	5/8 - 14	7/8 (0.88")	13/16 (0.80")
3/4	12	3/4 - 14	1 1/32 (1.04")	31/32 (0.97")
1	16	1 - 11	1 5/16 (1.30")	1 7/32 (1.22")
1 1/4	20	1 1/4 - 11	1 21/32 (1.65")	1 9/16 (1.56")
1 1/2	24	1 1/2 - 11	1 7/8 (1.88")	1 25/32 (1.79")
2	32	2 - 11	2 11/32 (2.35")	2 1/4 (2.26")



Komatsu 30° Flare with Metric Threads

Used extensively on Komatsu equipment, this connection has a 30° seat and parallel metric threads. Also referred to as JIS Metric, Komatsu fittings are sometimes confused with JIS 30° flare which has BSPP thread dimensions.

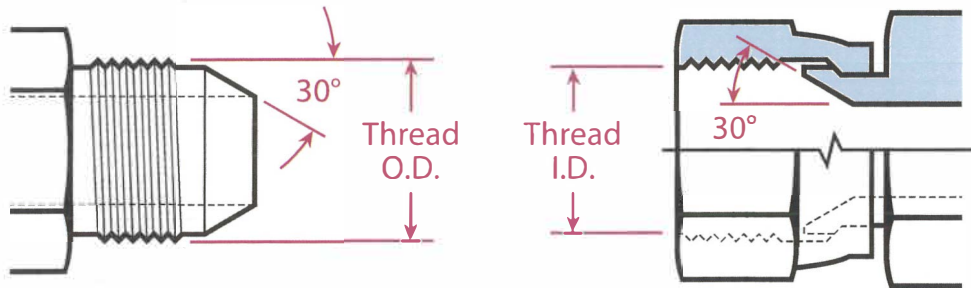

Dash Size	Metric Size Equivalent	Nominal Thread Size	Male Thread O.D.	Female Thread I.D.
06	9	M18 x 1,5	18 mm	16,5 mm
08	12	M22 x 1,5	22 mm	20,5 mm
10	16	M24 x 1,5	24 mm	22,5 mm
12	19	M30 x 1,5	30 mm	28,5 mm
16	25	M33 x 1,5	33 mm	31,5 mm
20	32	M36 x 1,5	36 mm	34,5 mm
24	38	M42 x 1,5	42 mm	40,5 mm

BSP & Metric Thread Identification Kit

31 heat treated aluminum thread gauges for fast and easy thread identification.

- 21 metric thread sizes
- 10 British Standard Pipe sizes
- Each size sample includes male and female threads
- Includes carrying case

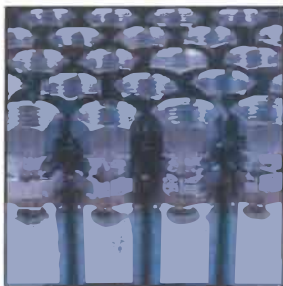

Nova Rubber Company
1-800-798-0361